

ASI5640  
(analog only)

ASI5641  
(digital only)

ASI5644  
(analog and digital)

## ASI564x Linear PCI Express Sound Cards

The ASI5640, ASI5641, and ASI5644 are professional PCI Express sound cards providing four stereo/eight mono inputs and outputs. Providing 12 play streams that are mixed to 4 balanced stereo outputs and 8 record streams fed from four balanced stereo inputs, the ASI564x family features AudioScience's unique "anything to anywhere" routing and mixing. The ASI5644 provides both balanced analog and AES/EBU inputs and outputs, while the ASI5641 has AES/EBU I/O only and the ASI5640 has analog I/O only. The maximum analog input and output level is +24dBu. Uncompressed PCM, in a choice of precision, is available for both recording and playback. For emerging surround sound applications, SSX™ mode allows multichannel streams of up to 8 channels to be played, recorded and mixed.

### FEATURES

- 12 mono/stereo streams of playback into 4 stereo outputs
- 8 mono/stereo streams of record from 4 stereo inputs
- Formats include 8, 16, 24, and 32 bit PCM with sample rates from 32kHz to 96kHz
- SSX™ mode for multichannel record, playback and mixing
- Balanced stereo analog inputs and outputs with levels to +24dBu (ASI5640, ASI5644 only)
- 24bit ADC and DAC with 110dB DNR and 0.0015% THD+N (ASI5641, ASI5644 only)
- AES/EBU inputs and outputs with sample rate converters on all inputs (ASI5641, ASI5644 only)
- Dedicated AES/EBU and Word clock Sync input (ASI5641, ASI5644 only)
- Short length PCI card format (6.6 inches/168mm)
- Up to 4 cards in one system
- Windows 2000/XP/Server 2003/Vista and Linux software drivers available
- CE, FCC, and RoHS compliant

# Block Diagrams

## STEREO/MONO MODE

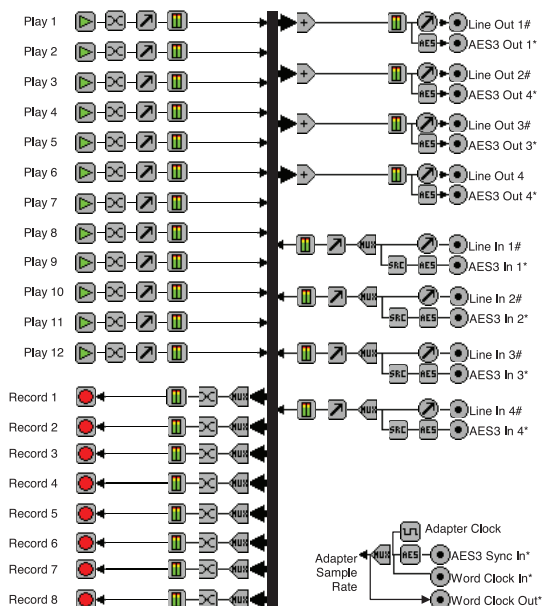

\* ASI5641 and ASI5644 only  
# ASI5640 and ASI5644 only

## SSX MULTICHANNEL MODE

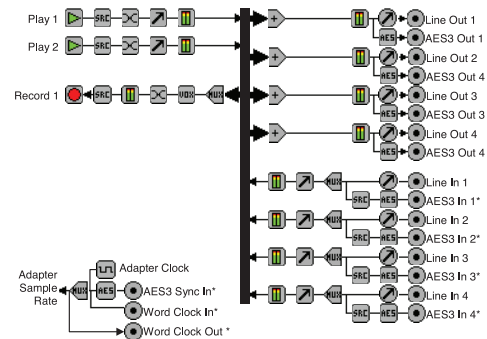

\* ASI5641 and ASI5644 only

- Key:
- Record Stream
  - Play Stream
  - Input/Output
  - Volume
  - Level
  - Mixer
  - Multiplexer
  - AES/EBU Tx/Rx
  - Meter
  - Sample Rate Converter
  - Channel Mode
  - Clock Source

## CONNECTORS

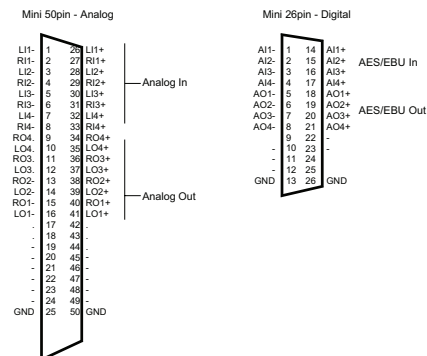

# Specifications

## ANALOG INPUT/OUTPUT<sup>2</sup>

- Type: Balanced
- Connector: Mini50 (SCSI-II type)
- Input Level: -10 to +24dBu in 0.5dBu steps
- Input Impedance: 10K ohms
- A/D converter: 24bit Over sampling
- Output Level: -10 to +24dBu in 0.5dBu steps
- D/A converter: 24bit Over sampling
- Load Impedance: 600 ohms or greater
- Dynamic Range<sup>1</sup>: 110dB (record or play)
- THD+N<sup>1</sup>: -96dB (0.0015%) (record or play)
- Frequency Response: 20Hz to 20kHz +0/-0.2dB  
20Hz to 40kHz +0/-3dB
- Inter-channel Phase: <0.1 degrees (record or play)
- Inter-channel Crosstalk: >110dB (record or play)

## DIGITAL INPUT/OUTPUT<sup>3</sup>

- Type: AES/EBU (EIA CP-340 Type I / IEC-958 Professional)
- Input/Output Impedance: 110 ohms
- Connector: Mini26 (SCSI-II type)
- Sample Rates: 32, 44.1, 48, 88.2 and 96kHz with sample rate converters on inputs

## SAMPLE RATE CLOCK

- Internal (Adapter): 32, 44.1, 48, 88.2 and 96kHz
- AES/EBU Sync In<sup>3</sup>: 32, 44.1, 48, 88.2 and 96kHz on dedicated AES/EBU input
- Word In<sup>3</sup>: 32, 44.1, 48, 88.2 and 96kHz
- Word Out<sup>3</sup>: 32, 44.1, 48, 88.2 and 96kHz

## SIGNAL PROCESSING

- DSP: Texas Instruments TMS320C6713@300MHz
- Memory: 8MB
- Audio Formats: 8 bit unsigned PCM  
16, 24, 32bit signed PCM  
32 bit floating point PCM

## BREAKOUT CABLES (INCLUDED)

- Analog: CBL1004: Mini 50 to Centronics 50 adapter  
CBL1044: Centronics 50 to 8 in and 8 out XLR
- Digital<sup>3</sup>: CBL1101: Mini 26 to Centronics 50 adapter  
CBL1114: Centronics 50 to 1 in, 4 out XLR, 1 BNC in, 1 BNC out (Word Clock)

## GENERAL

- Bus: X1 PCI-Express
- Dimensions: PCI short-length form factor (6.6"/168mm long)
- Weight: 8 oz (227g) max
- Operating Temperature: 0C to +70C
- Power Requirements: +3.3V@1.5A +12V @ 300mA

### NOTES:

- <sup>1</sup> Dynamic Range and THD+N measured using a +20dBu 1kHz sine wave sampled at 48kHz and A weighting filter.
- <sup>2</sup> ASI5640, ASI5644 Only
- <sup>3</sup> ASI5641, ASI5644 Only



© 2009 AudioScience. Specifications subject to change without notice.

